

DUMP TRUCK

Quarry

HD405-6/HD605-5

Max. Payload: **41.0metric tons/45.2U.S.tons**
Max. Gross Vehicle Weight: **73,175kg/161,320lb.**

Max. Payload: **63.0metric tons/69.4U.S.tons**
Max. Gross Vehicle Weight: **107,275kg/236,500lb.**



Model shown may include optional equipment.

Excellent Productivity&Fuel Economy

- High-output Komatsu engine with low fuel consumption
HD405:Komatsu SAA6D140E engine
HD605:Komatsu SAA6D170E engine
- Seven-speed, fully automatic K-ATOMiCS (Komatsu Advanced Transmission with Optimum Modulation Control System)transmission
- Oil-cooled multiple-disc retarder and optional exhaust retarder

Operator Comfort & Safety

- K-ATOMiCS transmission provides smooth acceleration and deceleration
- Hydropneumatic suspension for a smoother ride
- Wide, sound-suppressing cab ensures comfortable operator environment
- Maintains constant downhill travel speed (ARSC, Option)

More Uptime

- Sturdy, well-designed frame and tough body for quarry work
- Monitoring system for operational safety and reliability
- Adjustment-free caliper discs used for front wheel brakes

KOMATSU

Excellent Productivity & Fuel Economy

High-output Komatsu engine:

The power plant with turbocharger and aftercooler maximizes output.
 HD405:SAA6D140E
 15.2liter/488HP(364kw) at 2000RPM
 HD605:SAA6D170E
 23.15liter/715HP(533kw) at 2000RPM

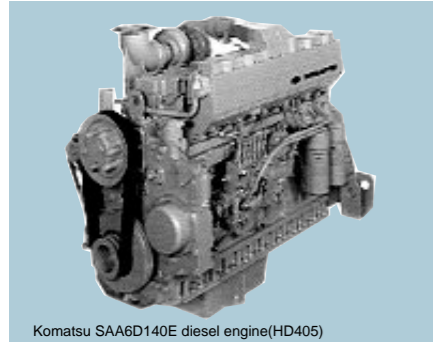

Komatsu SAA6D140E diesel engine(HD405)

Low fuel consumption:

High injection pressure creates an ideal fuel-air mixture for better combustion efficiency, while the ductile cast-iron pistons greatly reduce friction loss. For even higher combustion efficiency, each cylinder has four valves—two for intake, two for exhaust. The two helical intake ports produce optimum swirl for excellent combustion. The exhaust gas is smoothly and quickly ejected from the combustion chamber through the exhaust ports. All this helps to make the Komatsu-built engine fuel efficient.

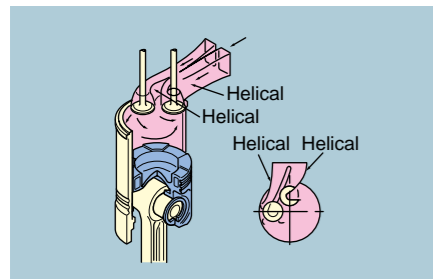

Seven-speed, fully automatic K-ATOMiCS transmission:

The K-ATOMiCS (Komatsu Advanced Transmission with Optimum Modulation Control System) automatically selects the optimum gear according to vehicle speed, engine speed and the shift position you've chosen. The result: the best gear for any driving situation.



K-ATOMiCS (Komatsu Advanced Transmission with Optimum Modulation Control System)

Oil-cooled multiple-disc retarder and optional exhaust retarder:

The truck can be decelerated without frequent use of the brakes, allowing you to travel more safely at higher speeds, even down long, steep slopes.

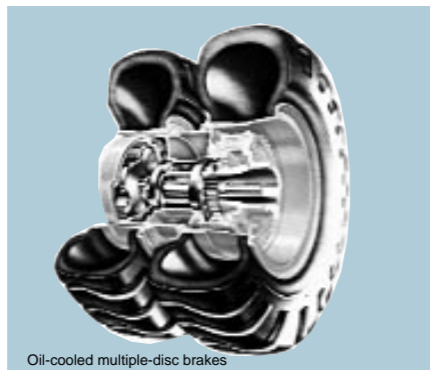

Oil-cooled multiple-disc brakes

A More Stable Ride in a More Maneuverable Truck

Long wheelbase and wide tread:

With an extra-long wheelbase, a wide tread and an exceptionally low center of gravity, the HD405-6/HD605-5 hauls loads at higher speeds for higher productivity, and delivers excellent driving comfort over rough terrain.

Big body: A wide target area makes for easy loading with minimal soil spillage and more efficient hauling.

Small turning radius: The MacPherson strut type front suspension has a special A-frame between each wheel and the main frame. The wider space created between the front wheels and the main frame increases the turning angle of the wheels. The larger this turning angle, the smaller is the turning radius of the truck.

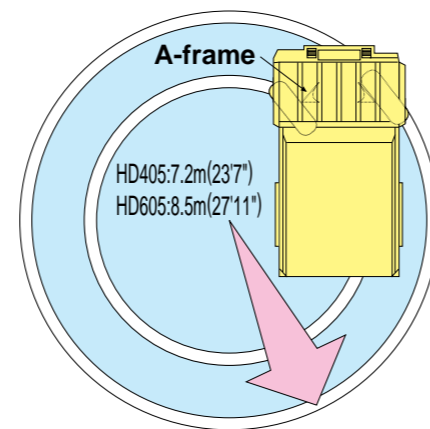

Enhanced Operating Comfort

K-ATOMiCS—smooth acceleration / deceleration:

An electronically controlled valve is provided for each clutch pack in the transmission, allowing independent clutch engagement/ disengagement. Moreover, it enables an ideal change in clutch modulation pressure and torque cut-off timing in response to traveling conditions. The result is smooth shifting and responsive acceleration.

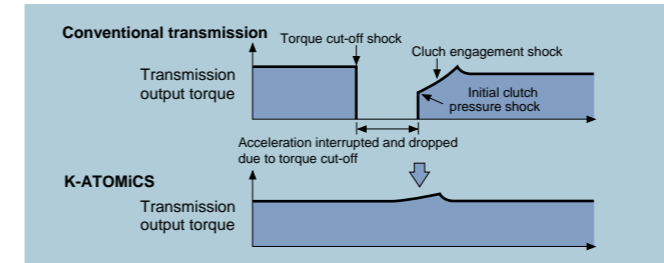

Hydropneumatic suspension:

All four wheels have hydropneumatic suspension with a fixed throttle damper control valve that greatly reduces pitching, rolling and bouncing over rough terrain.

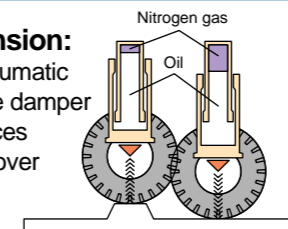

Ideal driving position settings: The five-way adjustable operator seat and the tilt-telescopic steering column ensure an optimum driving posture, for increased driving comfort and more control over the machine's operations.

See everything in quiet comfort: Wide windows in the front, side and back, plus plenty of space in the richly upholstered interior, give you a quiet, comfortable environment from which to see and control every aspect of your work.

More Uptime

Sturdy, well-designed frame:

Cast-steel components are employed in the main frame in high-stress areas where loads and shocks are most concentrated.

Adjustment-free brakes: The front service brakes are adjustment-free caliper disc type.

Easy maintenance: Greasing points have been centralized at three locations. Fuel and engine oil filters are also located together on the left-hand remote mount, for easy inspection from the ground.

Reliable hydraulic system: The oil cooler is installed below the retarder, improving the reliability of the hydraulic system during sudden temperature rises. Further, in addition to the main filter, a 52-micron line filter is located at the entrance to the transmission control valve. This system helps prevent secondary faults.

Excellent footwork and durable power line: By adopting electronic modulation on all shifting points, peak torque when shifting is reduced, raising the endurance of the power line.

Electronic devices for excellent operation: In the harness connection, a dual-lock connector is used to prevent loosening from vibrations and contact failure. Also, the base boards for controllers and other devices are fixed by moldin (with resin), realizing high resistance to water, dust and vibration.

New ultrahard, wear-resistant body ideal for quarry work

Komatsu and leading Japanese steel makers have developed a new ultrahard, wear-resistant steel with a tensile strength of 160kg/mm²(227,500psi), making it the hardest and most wear-resistant steel ever developed for dump truck bodies. The material is up to 25% harder than that used in previous Komatsu dump trucks, with about 2.5 times the hardness of widely used liner materials and a Brinell hardness rating of 500. By adopting the material in thicker plates, we have enhanced both productivity and durability. Further, our dump trucks have large-capacity bodies, ideal front and rear weight balance on tires and high maximum loading capacities.

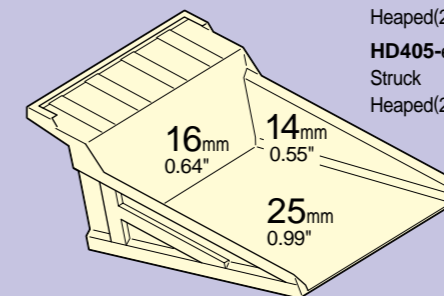

HD605-s:	
Struck	29m ³ 37.9cu.yd
Heaped(2:1)	40m ³ 52.3cu.yd
HD405-s:	
Struck	20m ³ 26.2cu.yd
Heaped(2:1)	27.3m ³ 35.7cu.yd

25% Harder
 (Compared to Komatsu's conventional materials)

Model shown may include optional equipment.

Advanced monitoring system



Vehicle monitoring system makes operation easier

The electronic display panel shows current vehicle conditions. If an abnormality occurs, the action code and service code are displayed. Thus, vehicle operation is easier and working efficiency is higher. At the same time, monitoring data is saved for later troubleshooting.

Service code display and memory function

The contents of each controller are displayed on the electronic display panel in service codes. The stored vehicle information can be downloaded to a personal computer (service tool). This enables a quick response to problems and shortens maintenance time. This also shows the truck's current condition and facilitates operation.

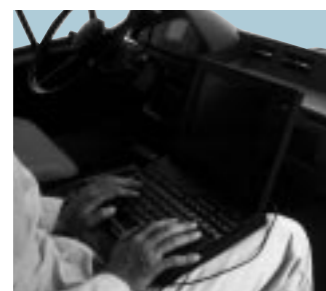

Action code display function

If an abnormality occurs on the truck, an "E" appears on the electronic display panel with the appropriate action code, which notifies the operator how to deal with the situation. This means the operator never misses an abnormality and can take appropriate corrective action.

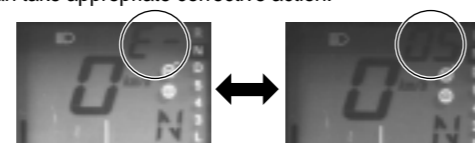

Messages interchange once every second.

Network functions

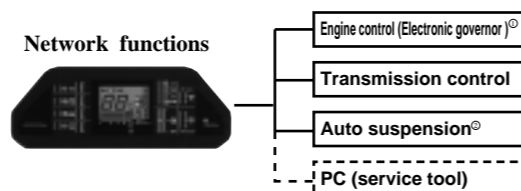

①HD405 OPTION ②HD405/605 OPTION

Value-enhancing options

Maintaining constant downhill travel speed

Auto Retard Speed Control (ARSC)

In addition to standard retarder, ARSC is available as an option. This allows you to simply set the downhill travel speed and go down slopes at a constant speed. As a result, you can concentrate on steering. The speed can be set at increments of 1 km/h per click (± 5 km/h of maximum speed setting) to match the optimum speed for the slope. Also, since the retarder cooling oil temperature is always monitored, the speed is automatically lowered to prevent overheating.

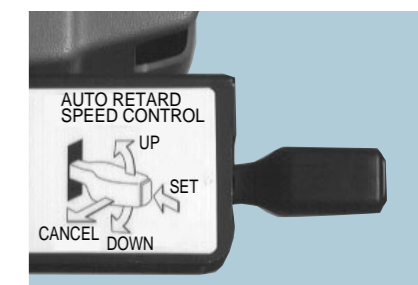

PLM II (Memory card payload meter)

This system allows the production volume and the working conditions on the dump truck to be analyzed and controlled directly via a personal computer. The system can store up to 2900 working cycles.

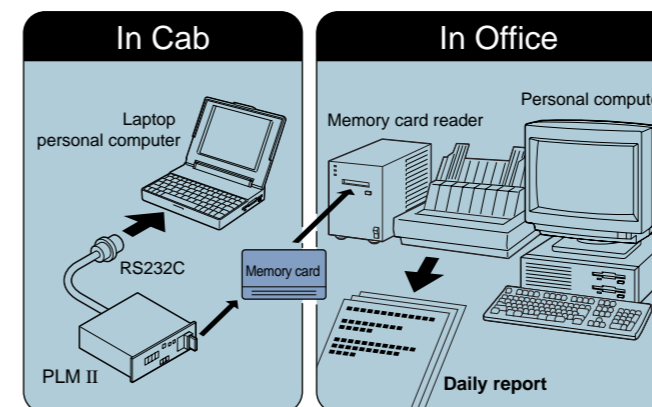

* The memory card, card reader and software for data processing are available as options.

Engine exhaust retarder:

The retarder capacity is 30% higher, permitting faster speeds on downhill slopes. This improves safety and hauling performance.

Three-mode hydropneumatic suspension (optional):

To further enhance driving comfort, automatic three-mode suspension is available as an option. This enables the operator to select one of three cushioning effects (SOFT, MEDIUM or HARD), depending on road conditions, for improved damping control.

Antilock braking system (ABS)

Using its outstanding electronics technology, Komatsu is the first in the industry to introduce ABS on construction machinery. This system prevents the tires from locking causing skidding under slippery conditions while applying the service brake.

Roll-Over Protective Structure (ROPS): This structure protects the operator and cab should the truck turn over. (meets SAES1040 APR88 and ISO 3471)

OPTIONAL EQUIPMENT

Cab:

- Air conditioner
 - Ashtray and cigarette lighter
 - Heater and defroster
 - Passenger seat (fabric)
 - Radio, AM
 - Radio, AM/FM with cassette
 - Seat belt, 78mm width
 - Seat belt, 78mm width for passenger seat
 - Seat covering, fabric
 - Sun visor, additional
 - Windows and windshield, tinted safety glass
- Body:**
- Body positioner (HD405)
 - Spill guard, 150mm (HD405) [90kg]
 - Spill guard, 250mm (HD405) [145kg]
 - Spill guard, 300mm (HD605) [165kg]

Lighting system:

- Back-up lights, additional
- Fog lights
- Work lights, RH and LH side

Safety:

- Additional rear view mirror (RH)
 - Automatic slip regulation (ASR)
 - Antilock braking system (ABS)
 - Auto-retard speed control (ARSC)
 - Buzzer, caution for dumping
 - Emergency steering, automatic
 - Front brake cut-off system
 - Retarder, engine exhaust
 - Roll-over protective structure with Fops [HD405/870kg] [HD605/1250kg]
 - Roll-over protective structure [HD405/770kg] [HD605/1150kg]
 - Tire stopper blocks
 - Under view mirror
- Gauge:**
- Dump position alarm & warning light

- Payload meter I, printer type
 - Payload meter II, memory card type
 - Revograph
 - Revograph/Tachograph
 - Tachograph
- Guard:**
- Engine underguard [HD405/25kg] [HD605/65kg]
 - Propeller shaft guard, front [15kg]
 - Propeller shaft guard, rear [HD405/25kg] [HD605/40kg]
 - Transmission under guard [HD405/95kg] [HD605/80kg]

Arrangement:

- Batteries for cold area arrangement (HD405)
- Batteries, 4X24 - volt 200-ah (HD605)
- Cold area arrangement (-30C thru 40C)
- High altitude arrangement
- Poor fuel (contained water) arrangement
- Sandy and dusty area arrangement

Others:

- Air dryer
- Alcohol injector
- Alternator, 75-ampere
- Auto greasing system
- Automatic mode selection controls suspension according to road conditions
- Centralized greasing
- Differential lock
- Engine side covers
- Fast fill coupler for fuel tank
- Fire extinguisher
- Gas charge tool
- Muffler (no body heating type)
- PM service connectors
- Radiator shutter, canvas type
- Spare parts for first servicing
- Reinforced floor guard (R.H) [80kg]
- Tool kit
- Vandalism protection

[] shows the amount of increased weight

Protection Functions Supported by Electronic Control

Item	Function
Downshift inhibitor	Even if the driver downshifts accidentally, a speed appropriate to the current gear is automatically set, preventing over-runs.
Over-run inhibitor	When descending grades, if the vehicle's speed surpasses the maximum setting for the current gear, the rear brakes automatically operate, preventing over-runs.
Reverse inhibitor	The vehicle is prevented from moving backward when operating the body.
Forward/Reverse shift inhibitor	This device makes it impossible to shift from forward to reverse when the vehicle's speed surpasses 4 km/hour.
Anti-hunting system	When running near a shift point, shifting is smooth and automatic.
Neutral safety	The engine is prevented from starting when the shift lever is not in neutral.

HD405-6 / HD605-5 SPECIFICATIONS

ENGINE

Model.....HD405: KOMATSU SAA6D140E
HD605: KOMATSU SAA6D170E

Type.....Water-cooled, 4-cycle

Aspiration.....Turbocharged and aftercooled

No. of cylinders.....6

Bore x stroke.....HD405:140 mm x 165 mm 5.5"x6.5"
HD605:170 mm x 170 mm 6.69"x6.69"

Piston displacement.....HD405:15.23 ltr. 930 cu.in
HD605:23.15 ltr. 1413 cu.in

Performance:

Gross horsepower.....HD405: **508 HP** 379 kW
HD605: **739 HP** 551 kW

Flywheel horsepower.....HD405:**488 HP** 364 kW (SAE J1349)
HD605:**715 HP** 533 kW (SAE J1349)

Rated RPM.....2000 RPM

Max. torque.....HD405:**221kg-m**1600ft-lb/**2.17kN-m** at 1400 RPM
HD605:**309kg-m**2235ft-lb/**3.03kN-m** at 1400 RPM

Fuel system.....Direct injection

Governor.....HD405: Max.-min. control
HD605: Electrical,all speed control

Lubrication system:

Lubrication method.....Gear pump, force-lubrication Filter

.....Full-flow type

Air cleaner.....Dry type with double elements and precleaner, plus dust indicator

TRANSMISSION

Torque converter.....3-elements, 1-stage, 2-phase

Lockup clutch.....Wet, single-disk clutch

Transmission.....Full-automatic, planetary gear type hydraulically actuated

Speed range.....7 speeds forward and one reverse

Forward.....Torque converter drive in 1st gear, direct drive in 1st lockup and all higher gears

Reverse.....Torque converter drive

Shift control.....Electronic shift control with automatic clutch modulation in all gear

Max. travel speed.....**70 km/h** 43.5 MPH

AXLES AND FINAL DRIVES

Final drive type.....Planetary

Rear axle.....Full-floating

Ratios:

Differential.....HD405: 3.125
HD605: 3.267

Planetary.....HD405: 4.737
HD605: 5.143

SUSPENSION

Independent, hydropneumatic suspension cylinder with fixed throttle to dampen vibration.

STEERING

Type.....Fully hydraulic power steering with two double-acting cylinder

Emergency steering.....Manual control

Min. turning radius.....HD405:**7.2 m** 23'7"
Min. turning radius.....HD605:**8.5 m** 27'11"

BRAKES

Service brakes:

Front.....Air-over-hydraulic, caliper disc type

Rear.....Air-over-hydraulic, oil-cooled, multiple-disc type

Parking brake.....Spring applied, caliper disc type actuates on driveshaft.

Retarder.....Air-over-hydraulic, oil-cooled, multiple-disc type, rear brakes act as retarders.

Emergency brake.....An emergency relay valve automatically actuates the service brakes and parking brake when air pressure drops below the rated level. Manual operation is also possible.

FRAME

Type.....Box-sectioned construction

Main frame material.....High-tensile-strength steel plate

BODY

Structure.....V-shape body

Material.....**160kg/mm²** 227,500 PSI high-tensile-strength steel

Heating.....Exhaust heating

Material thickness:

Floor.....**25 mm** 0.99"

Front.....**16 mm** 0.64"

Sides.....**14 mm** 0.55"

Target area (inside length x width).....HD405:**5590 mm x 3380mm** 18'4" x 11'1"
HD605:**6585 mm x 3870mm** 21'7" x 12'8"

BODY HOIST

Hoist cylinder.....Twin, 2-stage telescopic type

Hydraulic pump capacity.....HD405:**255 ltr./min.** 67.4 U.S. gal/min
HD605:**366 ltr./min.** 96.7 U.S. gal/min

Relief valve setting.....HD405:**210 kg/cm²** 3,000 PSI/**20.6MPa**
HD605:**210 kg/cm²** 3,000 PSI/**20.6MPa**

Hoist time.....HD405:10 sec.
HD605:10 sec.

CAPACITY

Standard body:

Struck.....HD405:**20 m³** 26.2 cu.yd
HD605:**29 m³** 37.9 cu.yd

Heaped (2:1,SAE).....HD405:**27.3 m³** 35.7 cu.yd
HD605:**40 m³** 52.3 cu.yd

Payload,maximum.....HD405:**41.0 metric tons** 45.2 U.S. tons
HD605:**63.0 metric tons** 69.4 U.S. tons

WEIGHT (approximate)

Empty weight.....HD405:**32050 kg** 70660 lb
HD605:**44200 kg** 97440 lb

Max. gross vehicle weight.....HD405:**73175 kg** 161320 lb
HD605:**107275 kg** 236500 lb

Not to exceed Max. gross vehicle weight, including options, fuel and payload.

Notes: 1. Remain under max. gross vehicle weight and ton-kilometers per hour, which are determined by tires.

2. Select tires that are appropriate for vehicle operating conditions.

Weight distribution:

Empty,front axle/rear axle.....HD405:45%/55%
HD605:44.5%/55.5%

Loaded,front axle/rear axle.....HD405:32%/68%
HD605:32%/68%

CAB AND ROPS

Dimensions comply with ISO 3471 and SAE J1040-1988c ROPS (Roll-Over Protective Structure) standards. (OPTION)

The cab is mounted on rubber pads and is well insulated.

TIRES

Standard, front and rear.....HD405: 18.00-R33★RADIAL
HD605: 24.00-R35★RADIAL

SERVICE REFILL CAPACITIES

Coolant.....HD405: **106 ltr.** 28.0 U.S. gal
HD605: **171 ltr.** 45.2 U.S. gal

Fuel tank.....HD405: **500 ltr.** 132.1 U.S. gal
HD605: **780 ltr.** 206.1 U.S. gal

Engine oil.....HD405: **37 ltr.** 9.8 U.S. gal
HD605: **52 ltr.** 13.7 U.S. gal

Torque converter, transmission and retarder cooling.....HD405: **90 ltr.** 23.8 U.S. gal
HD605: **69 ltr.** 18.2 U.S. gal

Torque converter, transmission HD605: **69 ltr.** 18.2 U.S. gal

Differential.....HD405: **45 ltr.** 11.9 U.S. gal
HD605: **95 ltr.** 25.1 U.S. gal

Final drive (left and right).....HD405: **26 ltr.** 6.9 U.S. gal
HD605: **63 ltr.** 16.6 U.S. gal

Hydraulic system.....HD405: **129 ltr.** 34.1 U.S. gal
HD605: **238 ltr.** 62.9 U.S. gal

Suspension (total).....HD405: **43.8 ltr.** 11.6 U.S. gal
HD605: **56.4 ltr.** 15.0 U.S. gal

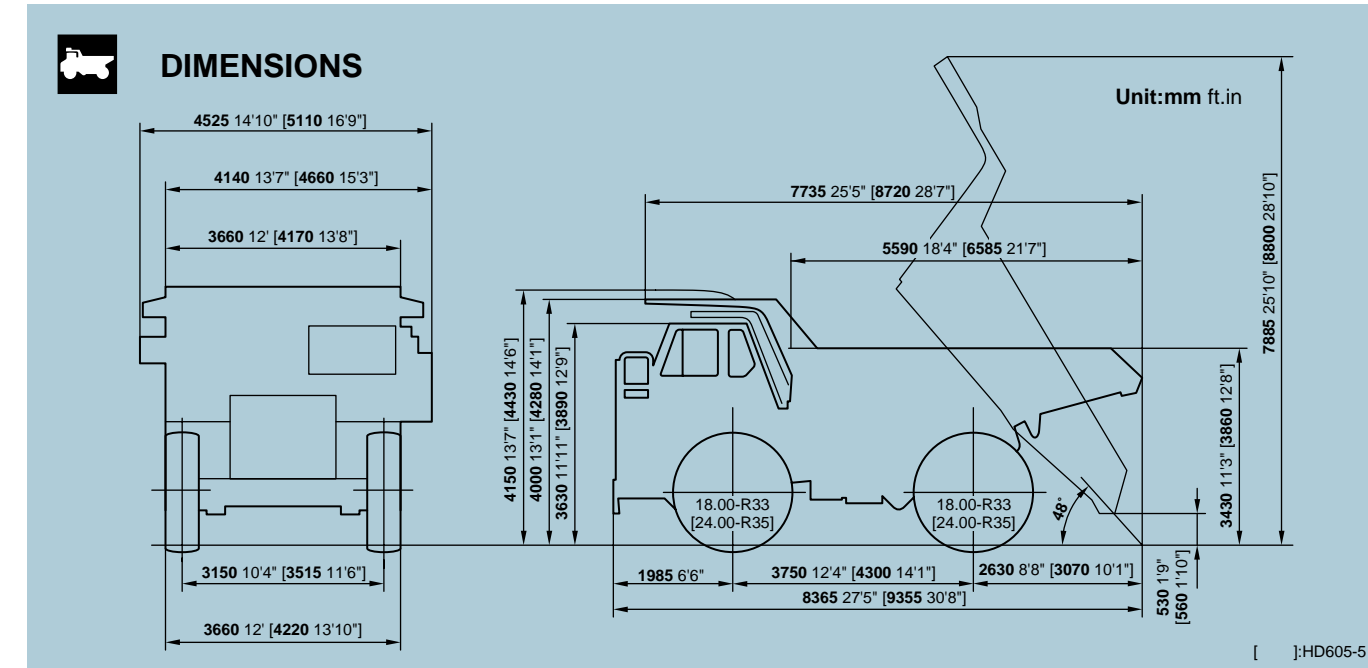

STANDARD EQUIPMENT

- | | | | |
|---|--|---|--|
| <p>Engine:</p> <ul style="list-style-type: none"> ●Alternator, 50-ampere ●Automatic idling setting system for engine low idle speed control (HD605) ●Batteries, 2 X 12-volt 170AH (HD405) ●Batteries, 2 X 12-volt 200AH (HD605) ●Engine, Komatsu SAA6D140E (HD405) ●Engine, Komatsu SAA6D170E (HD605) ●Starting motor, 1 X 11.0-kW (HD405) ●Starting motor, 2 X 7.5-kW (HD605) | <p>Cab:</p> <ul style="list-style-type: none"> ●Back-up alarm ●Cab, steel, sound suppression type ●Electronic display/monitoring system ●Seat, belt, 50mm width ●Seat, passenger ●Seat, suspension type, reclining with head rest ●Steering wheel, tilt able & telescopic <p>Lighting system:</p> <ul style="list-style-type: none"> ●Back-up light ●Hazard lights ●Headlights with dimmer switch ●Stop and tail lights and turn signal | <p>Safety:</p> <ul style="list-style-type: none"> ●Brakes with brake oil flow control valve (HD605) Emergency brake:actuates all service brakes (front, rear and parking, 3-way) ●Catwalk with hand rails ●Hand rail, platform, additional ●Horn, air ●Ladders, LH and RH side ●Rear view mirrors | <p>Others:</p> <ul style="list-style-type: none"> ●Body positionaer (HD605) ●Electric circuit breaker, 24-volt ●Hot area arrangement (-20C thru +50C) ●Mud guards ●Reinforced rock ejector ●Reinforced floor guard (LH) ●Tire guards (HD605) ●18.00R33 radial tires (HD405) ●24.00R35 radial tires (HD605) |
|---|--|---|--|

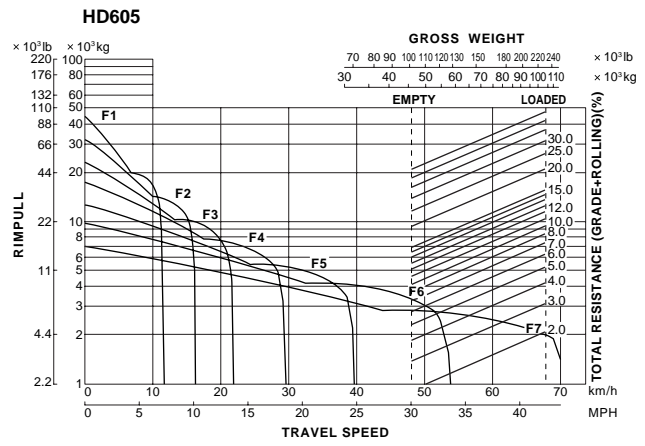
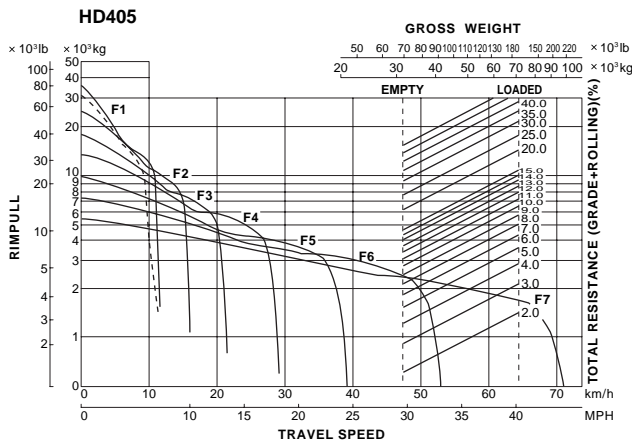

TRAVEL PERFORMANCE

To determine travel performance: Read from gross weight down to the percent of total resistance. From this weight-resistance point, read horizontally to the curve with the highest obtainable speed range, then down to maximum speed. Usable rimpull depends upon traction available and weight on drive wheels.

BRAKE PERFORMANCE

To determine brake performance: These curves are provided to establish the maximum speed and gearshift position for safer descents on roads with a given distance. Read from gross weight down to the percent of total resistance. From this weight resistance point, read horizontally to the curve with the highest obtainable speed range, then down to maximum descent speed the brakes can safely handle without exceeding cooling capacity.

HD405
Grade distance: 450 m (1480 ft)

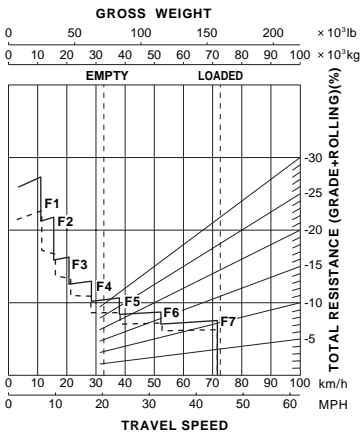

HD405
Grade distance: 900 m (2950 ft)

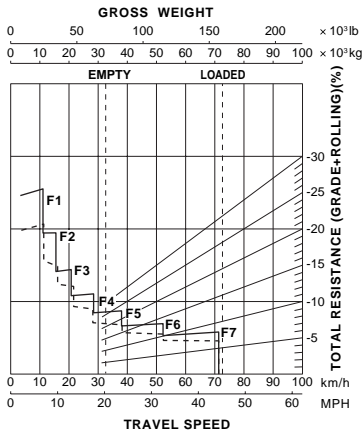

HD405
Grade distance: Continuous Descent

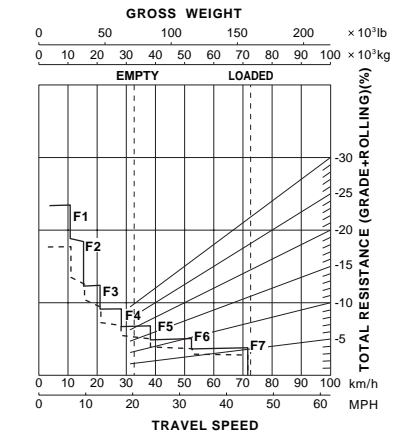

HD605
Grade distance: 450 m (1480 ft)

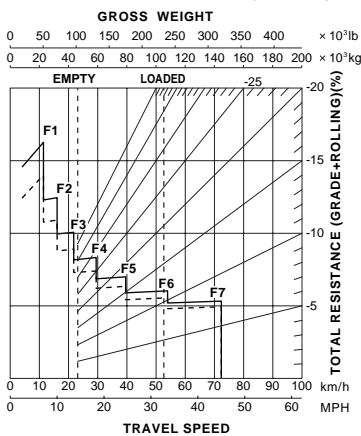

HD605
Grade distance: 900 m (2950 ft)

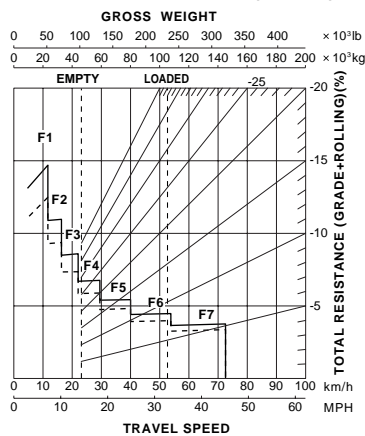

HD605
Grade distance: Continuous Descent

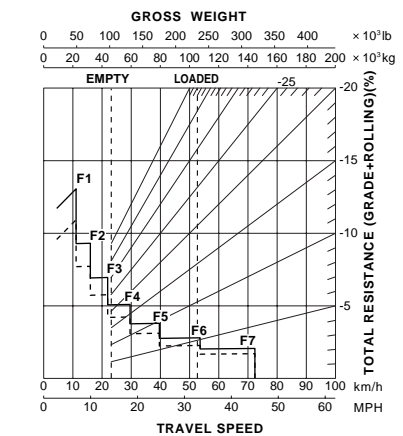

Performance line:
Solid lines... Exhaust retarder(OPTION)

Standard equipment may vary for each country, and this specification sheet may contain attachments and optional equipment that are not available in your area. Please consult your Komatsu distributor for detailed information.

