

TECHNICAL DATA

TANDEM ROLLERS

BW 141 AD-50, BW 151 AD-50

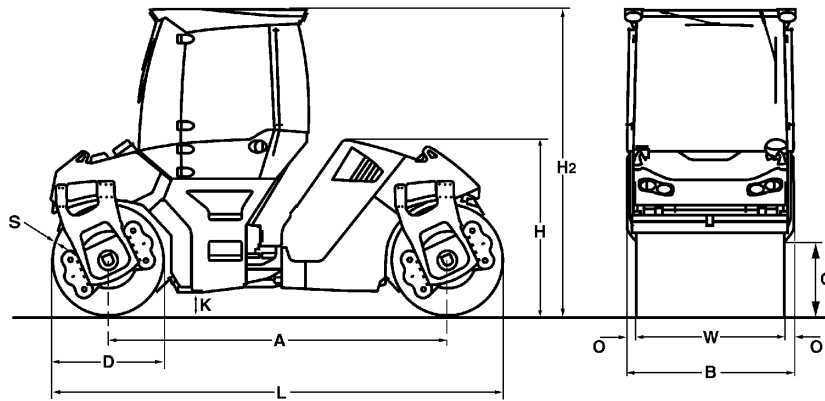



Dimensions in mm

	A	B	C	D	H	H2	K	L	O	S	W
BW 141 AD-50	3300	1664	730	1100	2240	3000	250	4400	82	16	1500
BW 151 AD-50	3300	1844	730	1100	2200	3000	250	4400	82	16	1680

Shipping dimensions in m3

BW 141 AD-50
BW 151 AD-50

without ROPS

16,400
 17,850

with ROPS

21,965
 24,341

Machine type	Compaction output (m3/h) at recommended soil layer thicknesses		
	Gravel, sand	Mixed soil	Silt, clay
BW 141 AD-50	140-280	120-250	50-120
BW 151 AD-50	150-310	130-280	60-180

Machine type	Compaction output (t/h) at different asphalt layer thicknesses		
	2-4 cm	6-8 cm	10-14 cm
BW 141 AD-50	35-60	50-130	80-150
BW 151 AD-50	35-70	60-130	90-160

Technical Data**BOMAG
BW 141 AD-50****BOMAG
BW 151 AD-50****Weights**

Operating weight CECE w. cab.	kg	6.900	7.600
Axle load, front CECE	kg	3.560	3.900
Axle load, rear CECE	kg	3.340	3.700
Static linear load, front CECE	kg/cm	23,7	23,2
Static linear load, rear CECE	kg/cm	22,3	22,0
Grossweight	kg	8.700	9.300

Dimensions

Track radius, inner	mm	4.480	4.390
---------------------------	----	-------	-------

Driving Characteristics

Max. travel speed	km/h	0- 11,0	0- 11,0
Max. gradeability without/with vibr.	%	40/30	40/30

Drive

Engine manufacturer		Kubota	Kubota
Type		V 3307 DI-T	V 3307 DI-T
Emission stage		Stage IIIa / TIER4i	Stage IIIa / TIER4i
Cooling		Liquid	Liquid
Number of cylinders		4	4
Performance ISO 14396	kW	55,4	55,4
Performance SAE J 1995	hp	74,3	74,3
Speed	min-1	2.200	2.200
Electric equipment	V	12	12

Brakes

Service brake		hydrost.	hydrost.
Parking brake		multi disc	multi disc

Steering

Steering system		oscil.artic.	oscil.artic.
-----------------------	--	--------------	--------------

Exciter system

Vibrating drum		front + rear	front + rear
Autom. vibr. shut off		standard	standard
Frequency	Hz	45/55	45/55
Amplitude	mm	0,71/0,28	0,71/0,27
Centrifugal force	kN	75/45	75/45
Centrifugal force	t	7,6/4,6	7,6/4,6

Capacities

Fuel	l	125,0	125,0
Water	l	600,0	600,0

Technical modifications reserved. Machines may be shown with options.

Standard Equipment

- 2 amplitudes / 2 frequencies
- Autom. vibration operation
- Individual vibration control
- Driver's seat, slewable (-15/+75°)
- laterally slidable with steering wheel
- V-belt protection
- Pressure sprinkling system with 2 pumps
- Back-up alarm
- Battery disconnect switch
- Folding scrapers

Optional Equipment

- ROPS cabin with seat belts
+ heating, Ventilation
+ 4 Working head lights
- ROPS cabin with air conditioning
- Rotary beacon
- 2 LED-lights for cabin roof (flatbeam)
- ROPS/FOPS
- Asphalt temperature display
- Crab-walk to both sides (170mm)
- BOMAG TELEMATIC START
- Compartments for documents and tools
- Outside mirrors
- Working lights
- Lights with german regulations
- Frequency 70Hz
- Additional weight 600kg (BW151AD-50)
- BOMAP compaction navigation with
GPS
- ECONOMIZER
- Edge cutter

